



**The Windsor®**  
*Convenience you can count on. The Windsor® home elevator fits in the space the size of a closet. A hoistway is built to house the elevator, giving it the appearance of traditional elevators. By using standard interior doors, the elevator blends seamlessly with its environment.*

**Windsor®**

When your lifestyle calls for a home elevator that can work within your existing home structure, turn to Access Industries for the solution.

Now you can enjoy the look and luxury of a home elevator without the expense and hassle of changing your foundation or space-hogging machine room. The Windsor® and Minivator® home elevators rest on your existing floor and are large enough to comfortably accommodate a wheelchair.

Both models offer stylish appointments, space-saving design, and a smooth, quiet ride. Yet both models are more affordable than you may think. And, the added convenience and flexibility to your home is incalculable.

Worry-free ownership. Both are equipped with all of the safety assurances and convenience features you'd expect from the industry leader. They are engineered to be low-maintenance and smoothly run for years to come. No matter which model you choose, be assured that you're getting the best in quality and innovation.

**Car interior**

*The white walls can complement your existing décor. Or select optional light oak laminate panels for a rich, warm interior. Optional handrail can also be added for your convenience. Stylish white accordion car gate folds neatly out of the way for a wide entry path.*



**Self-contained drive system!**

*The winding drum drive system is contained within the hoistway at the top of the track. Eliminates the need for a machine room which takes up valuable living space.*

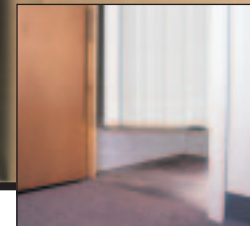

**No pit!**

*The car rests on the floor at the bottom landing, eliminating the need for costly pit construction required on other residential elevators.*



**Operating controls**

*Fully automatic controls. Optional key locks are available in the operating panel and hall station.*

**Optional recessed telephone box**

*Select the recessed telephone box in brushed bronze or stainless steel.*

**Safety features**

*Other standard safety features include an emergency stop button and alarm inside the car, a telephone jack which can accommodate a standard household phone, and much more.*



**Finished hoistway dimensions**

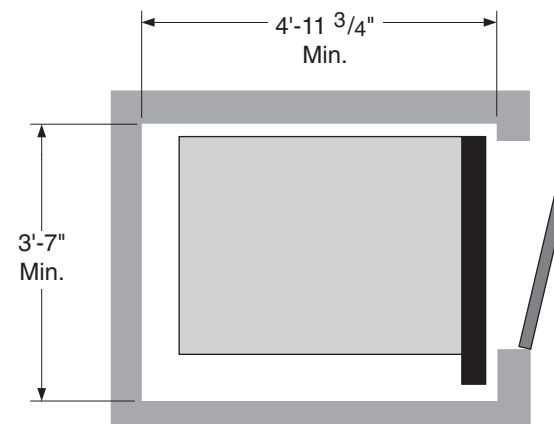

**Windsor general specifications:**

- No pit
- No machine room
- Lifting capacity: 500 lbs.
- Serves up to 16' between 2 floors
- Car size: 32 x 48 x 75-1/4" high
- Surface mounted light in car
- Fully automatic operation
- Winding drum drive system
- Hoistway doors interlock





**The Minivator®**

This model is designed for homes where space is at a premium and larger elevators are not practical. The structural impact on your home is minimal, ensuring the elevator can be installed and ready to use quickly.

Minivator®



**Open visual space**

Ivory finished steel wall panels with acrylic "windows" blend beautifully with virtually any home décor, while enabling passengers to see outside of the cab, maintaining an open, airy feel inside the cab. The car rides on two steel rails mounted to the wall, and passes through an easily-constructed opening between two floors.

**Minivator general specifications:**

- No pit
- No machine room
- Lifting capacity: 450 lbs.
- Serves up to 16' between 2 floors
- Minimum floor space: 35-3/4 x 54"
- Car size: 30 x 46 x 73-1/2" high
- Surface mounted light in car
- Constant pressure operation
- Operates on household current
- Winding drum drive system



**Makes the most of your living space**

No matter which floor the elevator is on, the opening between floors is attractively concealed. You can safely walk on the floor cover when the elevator is at the lower level. This feature opens up your living space, while giving you convenient access.



**Easy to own**

The Minivator was designed for your comfort and convenience. Push-button controls inside the elevator make it easy to operate. It comes equipped with an emergency stop button and you can add a telephone for your convenience. Key locks in the unit and hall stations prevent unauthorized access.



Manufactured in USA since 1947.



10M0403-PM105revB

A ThyssenKrupp  
business segment  
company

**Access Industries**

Committed to improving the quality of life. Access Industries, the world's most trusted name in accessibility solutions.

800.829.9760  
www.accessind.com



ThyssenKrupp

# TREASURE THE MOMENT

with Access Industries

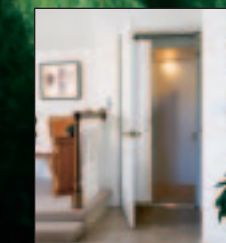

**Windsor®**  
Residential Elevators



**Minivator®**  
Residential Elevators

We make special moments happen.



A ThyssenKrupp  
business segment company